



*Bring the Indoors Out*

**OUTDOOR KITCHENS**

OUTDOOR LIVING

[www.StonewoodProducts.com](http://www.StonewoodProducts.com)



# Danver – Brown Jordan Kitchens

Let us help you build a completely customized steel outdoor kitchen to suit your style.



# Outdoor Kitchen Kits

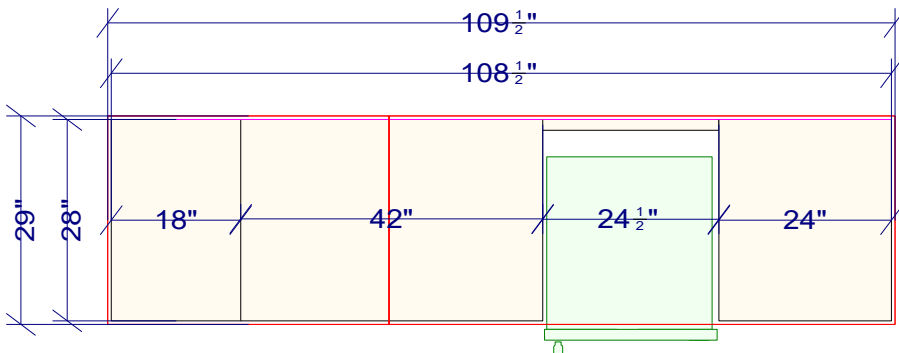

## The **Sesuit**

### Cabinetry

Pan Style Doors and Toe Kick  
Choose Cabinetry Color

### Appliances

Blaze 32" 3LTE Marine Grade Grill  
Blaze 32" Built-in Grill Cover

Choose Natural Gas or Propane

**\$12,999**

Countertop not included

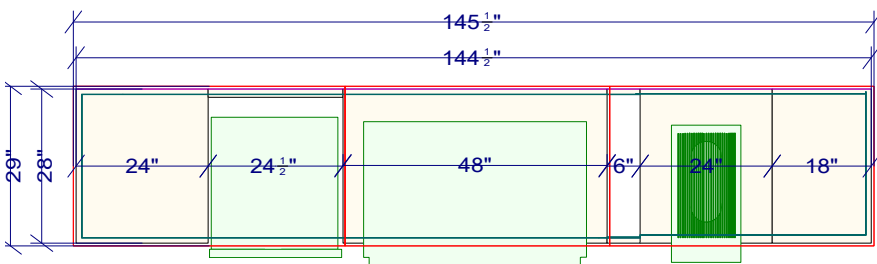

## The **Seaview**

### Cabinetry

Pan Style Doors and Toe Kick  
Choose Cabinetry Color

### Appliances

Blaze 32" 3LTE Marine Grade Grill  
Blaze 32" Built-in Grill Cover  
Blaze 24" Outdoor Rated Refrigerator  
Blaze Power Burner w/ Built-in Cover  
Bull 15" Single Bowl Stainless Steel Sink

Choose Natural Gas or Propane

**\$17,750**

Countertop not included

# Outdoor Kitchen Kits

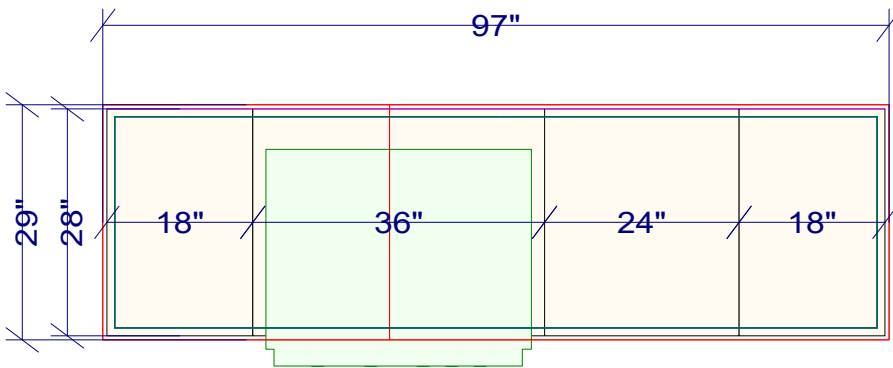

## The **Wychmere**

### Cabinetry

Pan Style Doors and Toe Kick

**Choose Cabinetry Color**

### Appliances

Blaze 32" 3LTE Marine Grade Grill

Blaze 32" Built-in Grill Cover

Blaze 24" Outdoor-Rated Refrigerator

**Choose Natural Gas or Propane**

**\$14,500**

Countertop not included

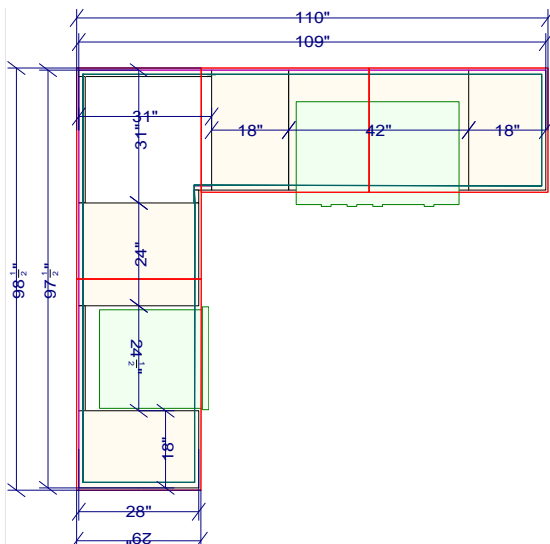

## The **Wianno**

### Cabinetry

Pan Style Doors and Toe Kick

**Choose Cabinetry Color**

### Appliances

Blaze 32" 3LTE Marine Grade Grill

Blaze 32" Built-in Grill Cover

Blaze 24" Outdoor Rated Refrigerator

**Choose Natural Gas or Propane**

**\$18,500**

Countertop not included

# Design Your Outdoor Kitchen

Answer a few questions so we can help you bring your dream kitchen to life!

Who is your contractor? \_\_\_\_\_  None

Who is your designer? \_\_\_\_\_  None

Who else is involved in this project? \_\_\_\_\_  None

What is your time frame? \_\_\_\_\_

Do you plan on entertaining? If so how many people on average? \_\_\_\_\_

How often do you plan to cook with your outdoor kitchen? \_\_\_\_\_

What is your approximate budget? \_\_\_\_\_

Do you plan on bringing utilities to your kitchen?

Water  Electricity  Propane  Natural Gas  A.V./Cable

Would you like custom or pre-built ready to use island?  Custom  Pre-Built

In order of importance, what would you like to include in your kitchen?

Gas Grill  Infrared Grill  Rotisserie  Side Burner(s)  Variable Burners  
 Power Burner  Warming Drawer  Pizza Oven  Refrigerator  Kegerator  
 Ice Machine  Cocktail Dispenser  Sink  Drawers  Cabinets  Trash  
 Paper Towel Rack(s)  Other:

In order of importance, are there any other options desired for your outdoor living space?

Fire Pits  Fire Bowls  Fire Table  Heaters  TV  Music  Roof  
 Pergola  Fan  Built-in Lights  Bar Seats  Cocktail Blender  
 Cutting Board  Other:

\_\_\_\_\_  
\_\_\_\_\_



# Design Your Outdoor Kitchen

What is the total square footage available for your kitchen? \_\_\_\_\_

Are there size constraints/obstacles? \_\_\_\_\_

What type of counter top is desired? \_\_\_\_\_

What type of layout is desired?



STRAIGHT



CORNER



U-SHAPE



L-SHAPE



STRAIGHT WITH ISLAND



2-PART U-SHAPE

What material would you like for the inside surface?  Stone  Wood  Stucco  Tile

What material would you like for the outside surface?  Stone  Wood  Stucco  Tile

## SKETCH YOUR KITCHEN

Which direction is North?  
Indicate on the compass below.

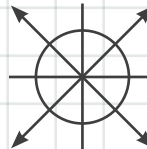

## TIPS:

- Your grill should be out of wind, to the northeast of your seating area.
- Refrigeration is essential to eliminate coolers.
- Consider a side burner for large stock pots. Install your burner on the dominant hand side of the grill.
- When choosing doors & drawers, use the same manufacturer to keep the handles consistent. Grill and refrigeration do not need to match.

Sales Rep. \_\_\_\_\_